

L. Polishchuk
O. Piontkevych
M. Burdeinyi
V. Trehubov

JUSTIFICATION FOR CHOOSING THE TYPE OF BELT CONVEYOR DRIVE

Vinnitsia National Technical University

The designs and dynamic properties of electromechanical and hydraulic drives for a belt conveyor have been analyzed to justify their selection. The main advantages and disadvantages of their operation have been formulated. It has been established that the hydraulic drive has advantages compared to the electromechanical one for installation in a built-in drive for a belt conveyor.

The design features and principles of operation of these drives have been described. Calculation schemes have been developed for the electromechanical and hydraulic drives of the belt conveyor. A mathematical model of the electromechanical drive has been constructed, taking into account the Voigt viscoelastic model for the conveyor belt, Hooke's laws for the deformation of stretching elements, equations of motion of the mechanical system, and electromagnetic phenomena in the asynchronous motor. Additionally, a mathematical model for the hydraulic drive of the belt conveyor has been constructed, which, besides the equations of motion of the mechanical system and the Voigt viscoelastic model for the conveyor belt, also includes the continuity equations of the working fluid flows in the hydraulic drive.

The parameters of the belt conveyor for studying the dynamic properties of the electromechanical and hydraulic drives, which are considered in the mathematical models, have been described. The mathematical models for the electromechanical and hydraulic drives have been solved using the Mathcad software package. Theoretical curves for cases of transient processes in the mechanical system of the belt conveyor without load and with load have been constructed. Transient processes of acting torques and angular velocities have been compared by the dynamic coefficient, and it has been established that the hydraulic drive has a better indicator by 1.78 times. It has also been established that the duration of the transient process in the drive with the electric motor exceeds this parameter in the drive with the hydraulic motor by 3.5 times.

It is recommended to use the built-in hydraulic drive for belt conveyors of mobile working machines because it has more advantages over the electromechanical one, and the dynamic indicators of the hydraulic drive provide better performance during operation.

Key words: belt conveyor, hydraulic drive, electric drive, mathematical model, transient processes.

Introduction

Short belt conveyors are often used on mobile and stationary machines for transporting bulk materials, providing good performance indicators [1, 2]. They are equipped with a flexible belt, drive and driven drums, and a motor. To ensure the compactness of belt conveyor drives, built-in drives are usually used together with the drive drum. These are also known as motor drums. Electromechanical and hydraulic drives are the most widespread [3].

Scientific works [4, 5] have been considered regarding the study of possible failures of belt conveyors. Models of dynamic processes [6, 7] in hydraulic drives of machines, which ensure stable operation [8], high-quality static and dynamic characteristics [9, 10], and rational selection of design parameters of equipment [11, 12, 13], have been analyzed. When checking the efficiency of hydraulic drives, it is also necessary to take into account the effect of temperature and viscosity of the working fluid in its channels [14, 15]. The results obtained by researchers allow meeting the current needs for designing new mobile machines in engineering, transport, agriculture, and other fields [16, 17].

When designing new mobile machines, the choice of the motor type for the belt conveyor is a relevant task for a modern engineer [18, 19]. It is necessary to analyze the main advantages and disadvantages of the types of drives, develop mathematical models, and study their operation.

The aim of this work is to justify the type of belt conveyor drive for installation on mobile machines.

Research results

In Fig. 1, *a*, the well-known structural scheme of an electric built-in drive is considered. The electric motor 1 is installed in an aluminum housing 2, and the gearbox 3, with a regular two-stage coaxial transmission, is attached to the housing 2 with a casing 4. Hollow trunnions 5 and 6, together with housings 2 and 4, form a

stationary structure. A fan 8 is installed in the hollow trunnion, in front of which screw-shaped guides 9 with blades 11 are secured.

Despite the apparent efficiency, the installation of the fan with guides complicates the design and reduces the efficiency. Despite the wide variety of structural designs of electric motor drums, their use as a drive is limited by insufficiently high specific power and efficiency, the complexity of smooth regulation of rotational speed and torque, the implementation of the specified control law, and the requirements for installing cooling and explosion-proof devices inside the drum housing.

These shortcomings can be eliminated or significantly reduced by using a hydraulic motor in the motor drum [20].

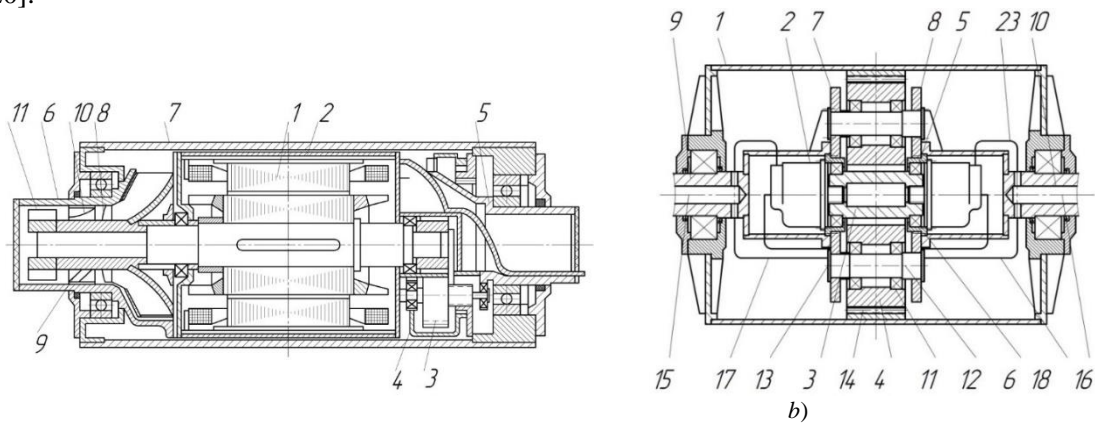

Fig. 1. Built-in drives of belt conveyors: (a) electromechanical, (b) hydraulic

The main factor determining the advantages of rotary hydraulic drives compared to electric drives is the physical principle of operation. The hydraulic motor operates with a specific force stress (pressure) of 6.3 to 25 MPa and above, while in the magnetic gap of the electric motor, the specific force stress is 0.7 MPa. Other factors determining the advantages of the hydraulic motor are:

- simplicity in transmitting forces and torques with small overall dimensions (the hydraulic motor occupies 12-13% of the volume of the electric motor) and mass (5-10 times lighter than an electric motor of the same power) combined with the ability to smoothly regulate torque and rotational speed over a wide range;
- the ability to frequently and rapidly change the direction of rotation, with small forces and moments of inertia of the hydraulic motor (for the same power, the mechanical time constant of the electric motor is 10-100 times less than that of the hydraulic motor);
- simplicity and reliability of overload protection using safety valves;
- ease of adjusting and setting some other parameters to the required values, especially speed, power, and torque;
- the overall efficiency of the hydraulic drive over almost the entire range of regulation is significantly higher than that of the electric drive with rheostat control;
- simplicity in switching on and off in automatic cycles of the actuators;
- low wear of the main working units and, consequently, high durability and relatively low operating costs.

These factors open up broad opportunities for the application of hydraulic drives in built-in drives. In Fig. 1, *b*, the structural scheme of a hydraulic built-in drive developed by the Department of Industry Engineering at VNTU is shown.

The structure includes the drum housing 1, into which the drive is built, consisting of hydraulic motors 2 for left and right rotation and a transmission mechanism made up of the drive gear 3 and intermediate gear wheels 4. The drive gear 3 is positioned coaxially with the axis of the drum, and its support trunnions are mounted on bearings 5, which are installed in cups 6 fixed on plates 7 and 8 rigidly connected to each other, forming a support element. Half-axes 9 and 10, inside which hydraulic motors 2 are installed, are attached to them. The drive gear 3 is mounted on the output shafts of the hydraulic motors 2, which are fixed on the plates 7 and 8 of the support element. Bearings 11 are pressed into the intermediate gear wheels 4, which are in mesh with the drive gear 3. They are mounted on axles 12, which are secured to the plates 7 and 8 by fixing strips 13 placed in slots on the end surfaces of the axles 12. The intermediate gear wheels 4, protruding beyond the support element, mesh with the ring gear 14, which is rigidly fixed to the inner surface of the drum housing 1. The half-axes 9 and 10, together with the support element, form a composite axis of the motor drum. Axial channels 15 and 16 are made inside the half-axes 9 and 10 for supplying and removing working fluid to and from the hydraulic motors 2. These channels are connected to the inlet and outlet openings of the hydraulic

motors 2 by radial channels and pipelines 17 and 18. The drum housing 1 is mounted on bearings covered with caps with sealing elements.

The motor drum operates as follows. When the working fluid is supplied through the axial channel 15, pipelines 17, to the working chambers of the hydraulic motors 2, the rotation of their output shafts occurs, which, through the drive gear 3 and intermediate gear wheels 4, drive the ring gear 14. The latter, through its rigid attachment to the inner surface of the drum housing 1, transmits torque relative to the composite axis. The working fluid that has lost energy is discharged through the outlet openings of the hydraulic motors 2, pipelines 18, and the axial channel 16.

By adjusting the flow rate and pressure of the working fluid, it is possible to control the rotational speed of the drum housing 1 (and thus the transport speed) and the torque, respectively. The direction of rotation of the drum housing 1 can be reversed using a hydraulic distributor. The motor drum design allows for the use of a single hydraulic motor if necessary.

When selecting the type of drive with different energy sources, one should be guided not only by specific indicators of energy consumption, material consumption, overall dimensions but also by the dynamic characteristics of these drives. During transient processes, the working links of the conveyor experience maximum loads, and prolonged oscillatory processes may occur in the mechanical system, potentially causing undesirable resonance phenomena. Therefore, it is important to compare the dynamic properties of electromechanical and hydraulic drives.

The principles of modeling these systems have been applied in the construction of simple calculation models of the electromechanical and hydraulic drives of conveyors to compare their dynamic properties.

In Fig. 2, a calculation scheme for the electromechanical conveyor drive is shown, where the motor shaft 1 with the rotor inertia I_r is connected via an elastic coupling, depicted as a spring with an equivalent torsional stiffness c and damping ν , and a gearbox with a gear ratio u , to the drive drum 2, which has an inertia I_2 . The tail drum, with an inertia I_3 , is subjected to the resistance moment M_0 from useful forces. The rotation angles of the motor shaft, drive drum, and tail drum are denoted by φ_1 , φ_2 , and φ_3 , respectively.

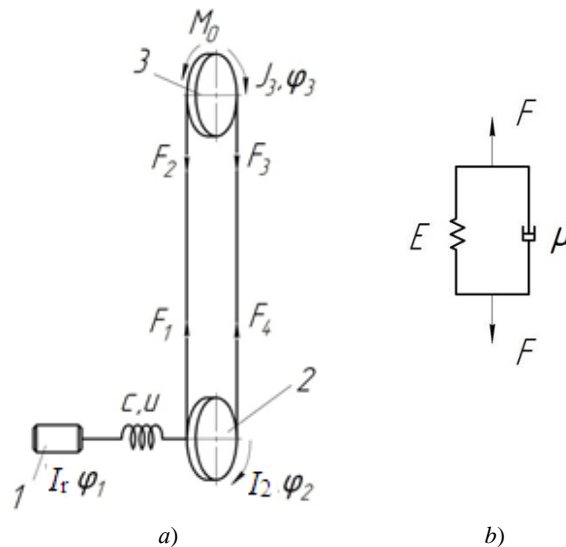

Fig. 2. Calculation scheme of the electromechanical conveyor drive (a) and calculation scheme of the belt (b)

Tension forces F_1, F_2, F_3 , and F_4 . are applied to the drums. The conveyor belt is represented by the Voigt viscoelastic model (see Fig. 2, b), according to which

$$F = A(E \cdot \varepsilon + \mu \cdot \dot{\varepsilon}), \tag{1}$$

where A – cross-sectional area of the belt; E – static modulus of elasticity of the belt; ε – relative elongation of the belt; μ – viscosity of the belt.

The absolute elongation of the belt Δl due to the rotation angles φ_2 and φ_3 and the radii of the drive r_1 and idler r_2 drums, respectively, is determined by the expression:

$$\Delta l = \varphi_2 r_2 - \varphi_3 r_3. \tag{2}$$

According to Hooke's law for tensile deformation

$$\Delta l = F \cdot l / (E \cdot A), \tag{3}$$

where l is the length of the conveyor belt.

The relative elongation and its derivative are defined as:

$$\varepsilon = \Delta l / l = (\varphi_2 r_2 - \varphi_3 r_3) / l, \quad (4)$$

$$\dot{\varepsilon} = (\dot{\varphi}_2 r_2 - \dot{\varphi}_3 r_3) / l = (\omega_2 r_2 - \omega_3 r_3) / l, \quad (5)$$

where ω_2 , and ω_3 are the angular velocities of the drive and tail drums respectively.

Taking into account the obtained relations (2) – (5), expression (1) will take the form

$$F = A \cdot E (\varphi_2 r_2 - \varphi_3 r_3) / l + A \cdot \mu (\omega_2 r_2 - \omega_3 r_3) / l = c_s (\varphi_2 r_2 - \varphi_3 r_3) + v_s (\omega_2 r_2 - \omega_3 r_3), \quad (6)$$

in which is the stiffness of the tape and its dynamic viscosity (7):

$$c_s = A \cdot E / l, \quad v_s = A \cdot \mu / l. \quad (7)$$

The equation of motion of a mechanical system has the form:

$$I_r (d\omega_1 / dt) + c (\varphi_1 - u\varphi_2) + v (\omega_1 - u\omega_2) = M_e,$$

$$I_2 (d\omega_2 / dt) + uc (\varphi_2 - u\varphi_1) + uv (\omega_2 - u\omega_1) + 2c_s (\varphi_2 r_2 - \varphi_3 r_3) r_2 + 2v_s (\omega_2 r_2 - \omega_3 r_3) r_2 = 0, \quad (8)$$

$$I_3 (d\omega_3 / dt) + 2c_s (\varphi_3 r_3 - \varphi_2 r_2) r_3 + 2v_s (\omega_3 r_3 - \omega_2 r_2) r_3 = -M_0,$$

$$\dot{\varphi}_1 = \omega_1, \quad \dot{\varphi}_2 = \omega_2, \quad \dot{\varphi}_3 = \omega_3,$$

and M_e is the moment on the shaft of the electric motor.

For the correct determination of the electromagnetic moment M_e , it is necessary to consider the relationships describing the electromagnetic state of the motor.

Electromagnetic phenomena in an asynchronous motor, taking into account magnetic saturation of the magnetic circuit, are described by equations:

To calculate the electromagnetic torque of the motor M_e

$$M_e = (3 / 2) \cdot p_0 \cdot u (i_{rx} \cdot i_{sy} - i_{ry} \cdot i_{sx}) \cdot (1 / \tau), \quad (9)$$

at each step of numerical integration of differential equations

$$i_x = i_{sx} + i_{rx}, \quad i_y = i_{sy} + i_{ry}, \quad i_m = \sqrt{i_x^2 + i_y^2}, \quad (10)$$

$$\tau = i_m / \psi_m, \quad \rho = di_m / d\psi_m, \quad (11)$$

simultaneously with solving the equations of motion, we perform numerical integration of the equations of the electromagnetic state of the motor

$$di_s / dt = A_s (u + \Omega_s \psi_s - R_s i_s) + B_s (\Omega_r \psi_r - R_r i_r), \quad (12)$$

$$di_r / dt = A_r (\Omega_r \psi_r - R_r i_r) + B_r (u + \Omega_s \psi_s - R_s i_s). \quad (13)$$

where i_s , i_r , u_s are column matrices of currents and voltages; i_x , i_y , are projections of currents on the x and y axes; A_r , B_r , A_s , B_s are connection matrices; Ω_s , Ω_r are rotation frequency matrices; Ψ_s , Ψ_r are flux linkage column matrices; R_s , R_r are active resistances. The index s indicates the belonging of the quantity to the stator winding, r – to the rotor.

The calculation of transient processes in the drive system of the conveyor is reduced to integrating equations (10) and (11) taking into account the dependence (12) and (13).

To investigate the transient processes in the hydraulic drive of the belt conveyor, we use the computational scheme of the mechanical system of the conveyor, shown in Fig. 3.

In the computational scheme of the hydraulic integrated drive of the conveyor, the hydraulic line from the pump 1 (see Fig. 3, *a*), driven by an electric motor, is supplied to the hydraulic motor 2, and from there to the drain. The maximum pressure created by the pump 1 is determined by adjusting the relief valve 3. The transmission mechanism of the drive with the gear ratio u is represented by a spring with torsional stiffness c . The moving parts of the conveyor are represented by two discrete masses 4 and 5. The first combined mass

includes the rotating parts of the drive device with the moment of inertia I_2 , to the second – the moving links of the conveyor transporting part with the moment of inertia I_3 , are attached. The tail drum's resistance moment M_0 , due to the useful forces acting on the conveyor, is consolidated. The angles of rotation of the hydraulic motor shaft, discrete masses 4 and 5, are denoted by $\varphi_1, \varphi_2, \varphi_3$, respectively. Forces of tension on the conveyor belt F_1, F_2, F_3, F_4 , are applied to the discrete masses 4 and 5. In this scheme, the conveyor belt is also represented by a rheological model, Foigt's model, with elastic-dissipative connections (see Fig. 2, b).

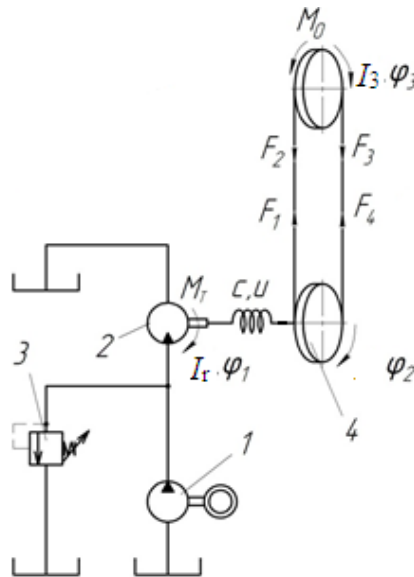

Fig. 3. Computational diagram of the hydraulic integrated drive of the belt conveyor

A simplified mathematical model of the hydraulic drive can be presented as a system of equations that takes into account the condition of fluid flow continuity and the equations (14) of motion of the mechanical part.

$$\begin{aligned}
 q_n \cdot n_n - \sigma \cdot p_1 - q_m \cdot n_m - K_1 \cdot V_1(dp_1 / dt) &= 0, \\
 I_r(d\omega_1/dt) + c(\varphi_1 - u\varphi_2) + v(\omega_1 - u\omega_2) &= M_h, \\
 I_2(d\omega_2/dt) + uc(\varphi_2 - u\varphi_1) + uv(\omega_2 - u\omega_1) + 2c_s(\varphi_2r_2 - \varphi_3r_3)r_2 + 2v_s(\omega_2r_2 - \omega_3r_3)r_2 &= 0, \\
 I_3(d\omega_3/dt) + 2c_s(\varphi_3r_3 - \varphi_2r_2)r_3 + 2v_s(\omega_3r_3 - \omega_2r_2)r_3 &= -M_0, \\
 M_h &= q_m \cdot p_1, \\
 \dot{\varphi}_1 &= \omega_1, \dot{\varphi}_2 = \omega_2, \dot{\varphi}_3 = \omega_3.
 \end{aligned}
 \tag{14}$$

To compare the dynamic characteristics of electromechanical and hydraulic conveyor drives, we will investigate the transient processes during their start-up. The parameters of the mechanical conveyor system with electromechanical and hydraulic drives are presented in Table 1.

Table 1

Parameters of the belt conveyor for studying the dynamic properties of electromechanical and hydraulic drives

Parameter	Numerical value	Parameter	Numerical value
$E, \text{N/m}^2$	$13.2 \cdot 10^6$	$p_1, \text{kg} \cdot \text{s}^2/\text{m}$	20.21
$q_n, \text{kg/m}$	164.3	$p_2, \text{kg} \cdot \text{s}^2/\text{m}$	2.14
$q_m, \text{kg/m}$	12.4	$c_1, \text{m/s}$	298.4
n_n, rpm	226.7	$c_2, \text{m/s}$	917
n_m, rpm	184.9	l_1, m	5
$I_2, \text{kg} \cdot \text{m}^2$	22.5	l_2, m	10
$I_3, \text{kg} \cdot \text{m}^2$	22.5	l_3, m	100
$I_r, \text{kg} \cdot \text{m}^2$	18.35	l_4, m	20
p_0	4	l_5, m	15
$\rho, \text{g/m}^3$	2.5	l_6, m	85

Theoretical curves were constructed for cases of transient processes in the mechanical conveyor system without load (Fig. 4) and with load (Fig. 5).

Calculations were performed using absolutely identical parameters of stiffness and viscosity of the drive system, as well as identical parameters of stiffness, viscosity, and inertial characteristics of the conveyor's transport section.

Comparison of transient processes of the acting torques and angular velocity of the drive drum in electromechanical and hydraulic drives shows that the dynamic coefficient for the hydraulic drive, $K_d = 2,8$, while for the electric drive, $K_d = 5$. The duration of the transient process to establish a stable speed in the motor drive exceeds this parameter in the hydraulic drive by 3.5 times.

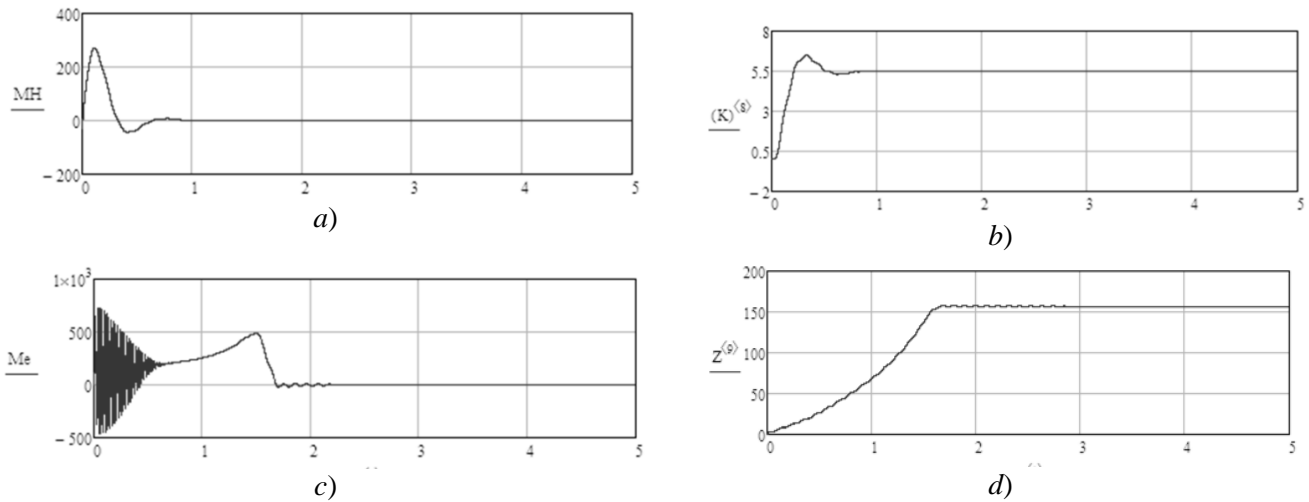

Fig. 4. Comparative characteristics of the dynamic properties of hydraulic (a, b) and electric (c, d) embedded drives without load

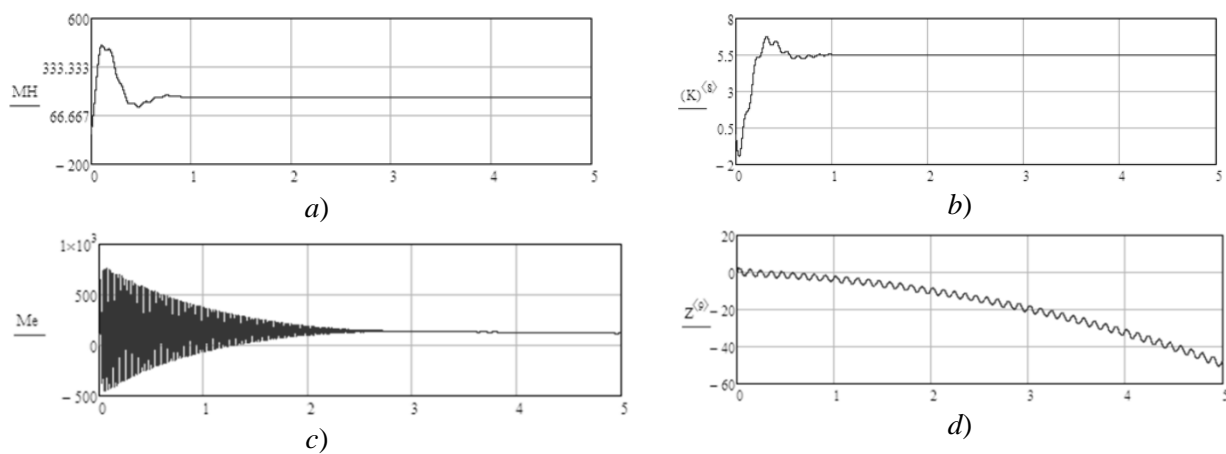

Fig. 5. Comparative characteristics of the dynamic properties of hydraulic (a, b) and electric (c, d) embedded drives with load

Thus, to reduce dynamic loads in the mechanical system of the mobile conveyor belt machine, preference should be given to the hydraulic embedded drive, which has better dynamic properties than the electromechanical one.

The scientific article and the work performed were prepared with the support of the National Research Fund of Ukraine 2022.01/0135.

Conclusion

It is recommended to use a hydraulic drive for the belt conveyor of the mobile machine, which is justified by the advantages in terms of structural, specific, and dynamic indicators. It has been established that the application of a hydraulic drive allows for a 3.5-fold increase in the speed of transient processes compared to an electric drive. The coefficient of dynamism for the hydraulic drive is 2.8, which is 1.78 times lower than that of the electric drive.

REFERENCES

- [1] Поліщук Л. К. Динаміка привідних систем і стрілових конструкцій стрічкових конвеєрів мобільних машин [Текст] : автореф. дис. на ... доктора технічних наук : 05.02.09 / Леонід Клавдійович Поліщук ; Національний університет "Львівська політехніка". Львів, 2017. 40 с.
- [2] Підйомно-транспортні машини. Розрахунки підйомальних і транспортувальних машин : підручник / В. С. Бондарев, О. І. Дубинець, М. П. Колісник [та ін.]. – К. : Вища шк., 2009. – 734 с.
- [3] Поліщук Л. К. Динаміка вмонтованого гідроприводу конвеєрів мобільних машин [Текст] : монографія / Л. К. Поліщук. Вінниця : ВНТУ, 2018. 240 с.
- [4] Parmar N. J. Failure Mode and Effects Analysis of Hydraulic Direct Drive of Belt Conveyor System Using a Hybrid Fuzzy Ahp and Fuzzy Topsis Method / N. J. Parmar, A. T. James, Z. A. Khan, M. Asjad. Available at SSRN 4519785, 2023. P. 27. <http://dx.doi.org/10.2139/ssrn.4519785>
- [5] Khmara L. A. Algorithm to calculate work tools of machines for performance in extreme working conditions / L. A. Khmara, S. V. Shatov, L. K. Polishchuk, V. O. Kravchuk, P. Kisala, Y. Amirgaliyev, M. Junisbekov. In *Mechatronic Systems 1*, 2021. P. 29-37. Routledge. DOI 10.1201/9781003224136-3
- [6] Березюк О.В. Огляд конструкцій машин для збирання та первинної переробки твердих побутових відходів // Вісник машинобудування та транспорту, 2015. № 1. С. 3-8.
- [7] Лозінський Д.О. Оптимізація електрогідравлічного розподільника з незалежним керуванням потоків / Д.О. Лозінський, Л.Г. Козлов, О.В. Піонткевич, О.І. Кавецький // Вісник машинобудування та транспорту, 2023. – №17(1). – С. 87-91. DOI: 10.31649/2413-4503-2023-17-1-87-91
- [8] Поліщук Л. К. Аналіз впливу параметрів системи керування на динамічні процеси гідропривода стрічкового конвеєра [Текст] / Л. К. Поліщук, О. В. Піонткевич, О. О. Коваль // Промислова гідравліка і пневматика, 2016. № 2(52). С. 37-47.
- [9] Піонткевич О. В. Вплив параметрів системи керування гідроприводом мобільної робочої машини на динамічні характеристики [Текст] / О. В. Піонткевич // Вісник машинобудування та транспорту. – 2016. – № 2(4). – С. 68–76.
- [10] Polishchuk L. Dynamics of the conveyor speed stabilization system at variable loads / L. Polishchuk, O. Khmara, O. Piontkevych, O. Adler, A. Tungatarova, A. Kozbakova. *Informatyka, Automatyka, Pomiarzy W Gospodarce i Ochronie Środowiska*, 2022. Vol. 12. No. 2. P. 60-63. DOI: 10.35784/iapgos.2949
- [11] Loveikin V. S. Minimization of oscillations of the tower crane slewing mechanism in the steady-state mode of trolley movement / V. S. Loveikin, Y. O. Romasevych, M. M. Korobko, A. P. Liashko, A. V. Loveikin, *Archive of Mechanical Engineering*, 70. 2023 DOI: 10.24425/ame.2023.146847
- [12] Romasevych Y. The method of calculating the maximum torque when jamming the auger of the screw conveyor / Y. Romasevych, V. Loveikin, O. Malinevsky, *Machinery & Energetics* 13(2), 2022. P. 83–90 DOI: 10.31548/machenergy.13(2).2022.83-90
- [13] Kozlov L. Optimization of Design Parameters of a Counterbalance Valve for a Hydraulic Drive Invariant to Reversal Loads / L. Kozlov, L. Polishchuk, O. Piontkevych, V. Purdyk, O. Petrov, V. Tverdomed, A. Tungatarova // *Mechatronic Systems*, W. Wójcik, S. Pavlov, and M. Kalimoldayev, eds., Vol. 1, Routledge, London, 2021 pp. 137–148. DOI: 10.1201/9781003224136-12
- [14] Mamedov A. Analysis of factors affecting destabilization of a viscous liquid flow in channels / A. Mamedov, R. Hnativ, O. Yakhno, A. Murashchenko, *International Journal of Applied Mechanics and Engineering* 28(3), 2023. P. 86–100 DOI: 10.59441/ijame/172899
- [15] Gubarev A. Calculations of unsteady processes in channels of a hydraulic drive / A. Gubarev, A. Murashchenko, O. Yakhno, A. Tyzhnov, K. Gromaszek, A. Kalizhanova, O. Mamyrbayev, *Mechatronic Systems 1*, Routledge, 2021. P. 149–160. DOI: 10.1201/9781003224136-13
- [16] Козлов Л. Характеристики мехатронного приводу під час просторового руху маніпулятора / Л. Козлов, С. Репінський, О. Паславська, О. Піонткевич // Наукові праці Вінницького національного технічного університету, 2017. – № 2. – 9 с. Електронний ресурс: <https://praci.vntu.edu.ua/index.php/praci/article/view/507>
- [17] Муращенко А. М. Розрахунок мобільних приводів машин / А. М. Муращенко, О. М. Яхно, О. П. Губарев, В. Г. Василюк, М. Коваленко // *Problems of Friction and Wear*. – 2019. – Vol. 3(84). P. 83 – 89
- [18] Polishchuk L. Application of hydraulic automation equipment for the efficiency enhancement of the operation elements of the mobile machinery / L. Polishchuk, L. Kozlov, Y. Burennikov, V. Strutinskiy, V. Kravchuk, *Informatyka, Automatyka, Pomiarzy w Gospodarce i Ochronie Środowisk* 9(2), 2019. P. 72–78. DOI: 10.5604/01.3001.0013.2553
- [19] Burennikov Y. Mechatronic hydraulic drive with regulator, based on artificial neural network / Y. Burennikov, L. Kozlov, V. Pyliavets, O. Piontkevych. *IOP Conf. Series Mater. Sci. Eng.* 209(1), 012071 (2017). DOI: 10.1088/1757-899X/209/1/012071
- [20] Поліщук Л. К. Гідрофікація транспортних засобів буртоукладальних машин / Л. К. Поліщук, Р. Д. Іскович-Лотоцький, Р. П. Коцюбівський // *Вібрації в техніці і технологіях. Всеукраїнський науково-технічний журнал*, 2003. №5 (31). С. 28 – 30.

Polishchuk Leonid – Dr. Sc. (Eng.), Professor, Head of the Department of Industrial Engineering, e-mail: leo.polishchuk@gmail.com

Piontkevych Oleh – Ph. D. (Eng.), Assistant Professor of the Department of Technology and Automation of Mechanical Engineering, e-mail: piontkevych@vntu.edu.ua

Burdeinyi Mykola – Post-Graduate Student the Department of Industrial Engineering, e-mail: 1m.14b.burdeinyi@gmail.com

Trehubov Vadym – Post-Graduate Student the the Department of Technology and Automation of Mechanical Engineering, e-mail: vadym.tregubow@gmail.com

Vinnitsia National Technical University, Vinnitsia

Л. К. Поліщук
О. В. Піонткевич
М. С. Бурдейний
В. О. Трегубов

Обґрунтування вибору типу приводу стрічкового конвеєра

Вінницький національний технічний університет

Проаналізовано конструкції та динамічні властивості електромеханічного та гідравлічного приводів для стрічкового конвеєра з метою обґрунтування їх вибору. Сформульовано основні переваги та недоліки їх експлуатації. Встановлено, що гідравлічний привід має переваги в порівнянні з електромеханічним для улаштування його у вмонтованому приводі стрічковому конвеєрі.

Описано конструктивні особливості та принципи роботи на цих приводах. Розроблено розрахункові схеми для електромеханічного та гідравлічного приводу стрічкового конвеєра. Побудовано математичну модель електромеханічного приводу, яка враховує в'язко-пружну модель Фойгта для стрічки конвеєра, закони Гука для деформації розтягу елементів, рівняння руху механічної системи та електромагнітні явища в асинхронному двигуні. Також побудовано математичну модель для гідравлічного приводу стрічкового конвеєра, яка враховує крім рівнянь руху механічної системи і в'язко-пружну модель Фойгта для стрічки конвеєра, ще рівняння нерозривності потоків робочої рідини в гідравлічному приводі.

Описано параметри стрічкового конвеєра для дослідження динамічних властивостей електромеханічного та гідравлічного приводів, які враховано в математичних моделях. Розв'язано математичні моделі для електромеханічного та гідравлічного приводів за допомогою пакету програм Mathcad. Побудовано теоретичні криві для випадків перехідних процесів у механічній системі стрічкового конвеєра без дії навантаження та з навантаженням. Порівняно перехідні процеси діючих моментів та кутових швидкостей за коефіцієнтом динамічності, та встановлено, що гідропривід має кращий показник в 1,78 рази. Також встановлено, що тривалість перехідного процесу в приводі з електродвигуном в 3,5 разів перевищує цей параметр у приводі з гідромотором.

Рекомендовано використовувати гідравлічний вмонтований привод для стрічкових конвеєрів мобільних робочих машин тому, що він має більше переваг над електромеханічним, а динамічні показники гідравлічного приводу забезпечують кращі характеристики під час експлуатації.

Ключові слова: стрічковий конвеєр, гідропривод, електропривод, математична модель, перехідні процеси.

Поліщук Леонід Клавдійович – д-р техн. наук, професор, завідувач кафедри галузевого машинобудування, е-mail: leo.polishchuk@gmail.com

Піонткевич Олег Володимирович – канд. техн. наук, доцент кафедри технологій та автоматизації машинобудування, е-mail: piontkevych@vntu.edu.ua

Бурдейний Микола Сергійович – аспірант кафедри галузевого машинобудування, е-mail: 1m.14b.burdeinyi@gmail.com

Трегубов Вадим Олександрович – аспірант кафедри технологій та автоматизації машинобудування, е-mail: vadym.tregubow@gmail.com